



The Forerunner

The Newsletter of St. John's Episcopal Church

February 2012

Website: www.stjohnssalemnj.org



The Pastor's Ponderings

Each of the “monotheistic” faiths, Judaism, Christianity and Islam have as a part of their yearly cycle, a time for reflection and repentance. Usually there is also some physical activity connected with the season. Fasting and abstinence come to mind from my childhood, but a pilgrimage might be included as well. We were urged to participate in activities of prayer, to give up an activity or treat, to practice acts of kindness and to embark on a regimen that might change a habit or two.

In a few weeks we will enter into the season of Lent. The name comes from a Teutonic word meaning “lengthening” or “spring season”, according to an online source. Although it is a small word, it is packed with meaning. Oftentimes we talk about a “Lenten practice.” It is a way of embracing activities that can be life-changing. We know that it takes time to break a habit, and it also takes time to acquire a good one. Time and practice.

The BCP (Book of Common Prayer) begins the season of Lent with an invitation – an invitation to participate in a Holy Lent. I like the idea of being invited, and especially to embrace a holy activity – something out of the ordinary manner of life. The BCP even offers suggestions as to how we might proceed. It advocates self-examination: Who are we really? Do we see ourselves as made in God's image? Or are we “self-made?” How do we relate to others? Do we see them as fellow pilgrims on a journey toward holiness? Or as obstacles to our view of the world, or our view of holiness? After self-examination, we are called to repentance: to turn from ourselves as center to God as our center, and out of that turning, to ask forgiveness. When was the last time that we asked forgiveness of someone we might have offended? When was the last time we extended forgiveness to another? Or accepted forgiveness for ourselves? The next practice is prayer, fasting and self-denial. At its simplest level, prayer is communication – communication with God and God with us. Prayer is both active and contemplative. It is speaking in all its forms, and listening; both for the still, small voice, and for the obvious command that reverberates in our very being. Prayer is silent and spoken; it is private and communal – just like life.

Someone once said that to fully embrace anything one must “feel it in the belly,” or words to that effect. For those who live with hunger, physical hunger, another discipline may be in order. But, for most of us, fasting would be one way to get our attention. It is not an option for everyone. The traditional rules allowed for one meal per day in the late afternoon, or early evening. There were exemptions, of course, owing to age or medical condition. The Episcopal Church has two required days of fast and abstinence. They are Ash Wednesday and Good Friday. Try these on and you may find that two are quite enough!

Self-denial is a familial Lenten practice. The question of “What are you giving up for Lent?” is common among many Christians. It is more than eschewing Twinkies, candy or even meat on Fridays. In accepting the truth that we are not the center of the universe, that our needs and wants are not what make us who we are, we may even discover that that which was once indispensable to use is something we can do without.
CONTINUES NEXT PAGE...

The Pastor's Ponderings - Continued:

There is a certain freedom in that discovery.

Finally, there is the injunction to read and meditate on God's Holy Word. There are always stories about family Bibles; some ornate, some not, they serve as dusty relics laid in safe places, and that they still creak when opened, like unused books. These days they may get more use if they contain family genealogy data, but more often than not, they are decorative and not invited into daily or weekly life. The Word of God is more than the "thou shalt nots" or condemnations, or wars or other forms of "holy mayhem." It is not a book of answers but rather a book of encounters. The Bible speaks volumes (that is what it is) of God's enduring connection with mankind with creation and the gift of relationship, wholeness and holiness offered time and again. That gift is one of salvation and the gift of connection with God. These are central themes of Holy Scripture. Lent offers a special time to review our interaction with God and with one another, and if necessary, to renew that connection.

If all this seems a little complicated, it is perhaps because I have made it so. The whole idea is that the Church, venerable institution that it is, has issued to each one of us an invitation to observe a holy Lent. It is an invitation written in ashes rather than gold leaf; it is a journey of 40 days and it leads from the cross to resurrection. Come let us journey together.

Prayerfully,



Fr. Steve

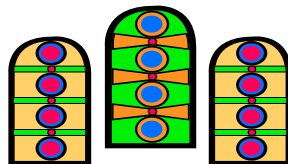

St. John's Episcopal Church – Salem, NJ – Established 1722

Parish Office: 856-935-1798 Fax at office: 856-279-2121

E-Mail: stjohnssalemnj@comcast.net

Website: www.stjohnssalemnj.org

Priest-in-Charge: The Rev. Steven E. Carroll Home: 856-376-3557/cell: 856-236-4337
fathersteve@comcast.net

Senior Warden: Ron Magill 856-935-5398

Junior Warden: Virginia Sisco 856-358-0307

Treasurer: Joe Kimber 856-935-2288

Secretary: Marjorie Warren 856-935-1798

Minister of Music: William F. Clisham, Jr. 908-472-7597

Forerunner Editor: Rosie Carroll 856-376-3557

stjohnssalemnj@comcast.net

wfclish@aol.com

rsmrycarroll@yahoo.com

From the Editor:

The Deadline for the March issue is February 21st. There is a "shoebox" on the shelf outside the church office in which you may place items for The Forerunner, or you can email to rsmrycarroll@yahoo.com. Also, if you would like to change the way you receive your Forerunner (e-mail, pick-up, or post office), please leave a message with the church office. Your questions and comments are always welcome. /rc

SENIOR WARDEN'S COLUMN

As your newly elected Senior Warden, first allow me to say Thank You; for your trust in me that I will carry out the work of our Parish, for your confidence that I will adequately represent you who comprise the "church," and for the privilege, along with all members of vestry, to speak on your behalf at Vestry meetings.

In my opinion, my role as Sr. Warden is a continuation of my previous position as a member of the vestry. I am here to serve and represent you the individual members of our congregation and parish.

You elect vestry persons to be your spokespersons, to speak on your behalf and to oversee the day to day operation of our parish. We do that best when you let one of us know if and when you have a question, concern, or opinion you wish expressed. Your position can be presented to vestry anonymously or your concerns may be expressed by name as you wish.

I am a relatively new member of St. John's Episcopal Church and in fact a rather new Episcopalian. I come from a long line of Presbyterians (seven generations of them) with a few fundamentalist ancestors added to the mix just to keep everyone guessing! I take worship seriously. Our church's formal style of worship shows great respect for our Lord. Some have referred to it as lots of "smells and bells" but it is oh so much more. We may not routinely clap our hands or raise our arms in praise but the beauty and depth of our worship is just as alive.

I hope that those members and friends who may not have been out on Sunday for a while will come and worship at one of our Sunday's services. Whether you are an early riser and wish to come for a quiet, simple service at 8:00 AM in the Chapel or wish to experience one of Salem County's most beautiful choirs and organ at 10:30 AM, you will surely be welcomed.

As the year progresses, I hope to use this column to keep you abreast of what the vestry is doing and what decisions have been made on your behalf. Your responsibility is to let me, or any vestry person, know when you have something to be said at the vestry level. My home telephone number is (856) 935-5398, my email is local_art@comcast.net, my mailing address is 324 Walnut Street Road, Salem, NJ 08079. Use any one of these methods to reach out to me.

Ron Magill
Senior Warden



FROM THE JUNIOR WARDEN

Greetings from your "senior" Junior Warden. My husband, Dick (who died in 2003), and I moved to Salem County in 1972. We transferred to St. John's in 1997. I became a Vestry member for the first time in 2001. I have learned that mind-reading is one of the requirements for Junior Warden. Because I lack such talent, I shall greatly appreciate hearing or reading your ideas and questions. It would be great to learn what ideas anyone may have to attract new people to worship with us.

Virginia Sisco
Junior Warden



ANNUAL MEETING REPORT

St. John's Annual
Congregational Meeting was
held January 22nd, following

the 10 am Holy Eucharist. A lovely luncheon, catered by the Salem City Café, was served and then the meeting was called to order.

Elections were held first with Ron Magill being elected Senior Warden and Virginia Sisco elected Junior Warden. Elected to Vestry were Bill Mecum, Elizabeth Vanaman, and Nate Gable to three-year terms and Ralph (Bud) Magill for a 2-year term. Convention and Convocation Delegates are Jennifer and Earle Robinson and John Ensselen, with alternates being Rosie Carroll, Sue Harker and Marcie Frame.

Organizational reports were presented next, with several being presented as written, and others with minimal verbal embellishments. Copies of reports are available in the church office.

The Budget was discussed as presented in the meeting hand-out and raised several questions. It was decided to table its passage until it could be further clarified, and issues resolved. It was noted that all meetings at St. John's are open (unless specifically announced otherwise) and anyone may attend any finance, outreach, liturgy or other committee meeting with voice but no vote. Future meetings of all committees will be highly publicized so parishioners with questions or suggestions may attend as desired.

The resignation of Bill Pankonien as Chair of the Buildings and Grounds committee was announced as was the resignation of Joe Kimber as Chair of the Finance Committee. Joe Kimber will continue as Treasurer. Both resignations are effective as of this meeting. Their work has been very much appreciated. Warren Bye will help with building and ground concerns for the time being and the position of Chair of the Finance Committee remains open as of this writing.

There being no further business for the meeting to consider, it was adjourned.

Quilters Break Their Record!

Prior to the Annual Meeting, parishioners had the opportunity to view the beautiful quilts made for the Ronald McDonald House residents in Camden. Our quilters broke their previous record of the number of quilts completed in a year by finishing 50 quilts in 2011! WOW!



- Congratulations! To Kassandra Laning who has been nominated by the administration at Fairleigh Dickinson University to join the National Society of Leadership and Success, Sigma Alpha Pi. This is not a fraternity/sorority but a leadership honor society which Kassandra earned because of her academic accomplishments and leadership potential
- Welcome! To Kevin and Maxine Hengeli who are new to Salem and new to St. John's. We are very glad to have them with us.
- Please keep Fr. Rick Cromwell (from St. George's Church in Pennsville) in your prayers as a fall shortly after Christmas landed him back in hospital and he is now in physical therapy/rehab.
- Donna Donohue, our seminarian has returned from a 10-day seminary-sponsored mission trip to El Salvador. She will share her story with us soon in an adult-forum offering. She described the experience as life-changing.

HELP IS NEEDED

Men, Women, Couples or Singles - our "Monday Daisies" needs YOU! Mr. Jim Paras delivers our altar flowers to the homebound on Mondays and currently is working alone. Helping hands would be most welcome! All that is required is that you pick up the flowers from the parish hall kitchen and deliver them as designated. Talk with Mr. Paras for more details.

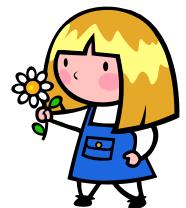

SHROVE TUESDAY PANCAKE SUPPER

WHAT: Supper of pancakes, sausage, applesauce
WHERE: St. John's Parish Hall
WHEN: Tuesday before Ash Wednesday, February 21st, 5 to 7 pm
WHO: The congregations of St. John's Church and possibly that of Our Merciful Savior



At this writing the Pancake Supper is still in the planning stages and further details have not been worked out, so watch your

Sunday Bulletin for more information.

MUSIC AROUND THE COUNTY

PICTURES AND PIPES – A silent film festival with theater organ accompaniment, featuring Charlie Chaplin, Buster Keaton and Fatty Arbuckle with renowned Theater Organist, Wayne Zimmerman, will be held on Saturday, February 25th, at 7 pm, at the Alloway Baptist Church (41 West Main Street, Alloway, NJ). Admission is free. For more info: www.VisitSalemCountyNJ.com or call 1-877-658-6871



+Christian Symbols +



40 This number appears many times in Scripture, often indicating a time of trial or testing, or simply marking something significant. It rained 40 days and nights during the Great Flood. Israel wandered in the wilderness for 40 years. Jesus fasted for 40 days and was with the disciples for 40 days between his resurrection and ascension. Taking this symbolic number to heart, the Christian church has long observed 40 days of Lent (not counting Sundays).

(from The Newsletter Newsletter, Feb. 2012)

COMMUNITY LENTEN PROGRAM

The Salem Area Ministerium has set its Lenten Program for 2012 and it is as follows:

Wednesday evenings
6 pm soup and bread supper
7 pm worship service

Lent 1, 2/29: Haven United Methodist Church
Lent 2, 3/7: Spirit Life Fellowship Church
Lent 3, 3/14: Emanuel Lutheran Church
Lent 4, 3/21: Mt. Hope United Methodist
Lent 5, 3/28: Walnut Street Bible OR 1st Baptist

April 6th Good Friday: 12 to 3 pm at Haven United Methodist Church

April 8th – Easter – 6:30 AM – under the Oak at the Friends Cemetery (bring your own chair).

ST. JOHN'S FEBRUARY COMMITTEE MEETINGS

Vestry:

Sunday, February 12th – following Coffee Hour. The Vestry meets on the second Sunday of each month.

Finance Committee:

Monday, February 6th, 2 pm in the Parish Hall.

Liturgy Committee:

Wednesday, February 8th, 5 pm in the Library.

Please note that all meetings are open to parishioners of St. John's and that they may have voice (in the "call to the public") but no vote. Should a particular meeting need to be restricted to committee members only, it will be advertised as such.



ANNUAL DIOCESAN
ACOLYTE FESTIVAL
Saturday, 11 February 2012
Trinity Cathedral, 9:30 am to 3:30pm

The Diocesan Acolyte Festival offers acolytes an opportunity for fellowship and learning in a daylong celebration of their ministry.

Workshops and a special celebration of the Eucharist make this a day to remember. Take a look at the Diocesan website for information on the workshops and more on the festival.

<http://newjersey.anglican.org/>

David Miller will be coordinating St. John's trip to Trenton. Parents of acolytes and guests are welcome to join the closing service, which begins at 2 pm.



02/05 Casie Kates
02/08 Richard Frieze
02/08 Curt Harker
02/10 Aiden Willis
02/11 George Githens
02/12 Betty Wismer
02/13 Jonathan Buck
02/17 Daphne Miller
02/19 Jennifer Robinson
02/20 George Neff
02/22 Kathy Paras
02/24 Joe Buck
02/26 Jim Davis



02/01 Bill and Mary Anne Clisham
02/05 Father Joe and Sharon Moore



(This column is an experiment. It will run for a few months and see what the response is. If you have something to sell or trade, or if you are looking to buy a gently used item, write it up, being sure to include a contact phone number, and submit it to the Forerunner either by email or via the box on the counter outside the church office.)

- TO SELL: One electric grill/griddle/waffle iron with removable trays. Call Virginia at 856-358-0307.
- FREE for the taking: One vintage round patio table, white with "glass" top, umbrella and umbrella base. No chairs. Call Rosie at 856-376-3557



Dear Friends at St. John's and beyond:

Ecclesiasticus 31:20:

Healthy sleep depends on moderate eating;
he rises early, and feels fit.
The distress of sleeplessness and of nausea
and colic are with the glutton.

There it is in black and white! I am a glutton! Who would have thought it! I have been feeling sort of "punky" lately, my belly sort of ached, and I was just not myself. I thought it was because I have not been sleeping too well these past few months, what with anxiety over what I was going to get (yes, and GIVE) at Christmastime, and about the possible end of the world in 2012, and if my sweetie, Ruth, from the Stone Garden, would continue to be my "best girl" or not when spring comes. There were so many goodies left about for me that my pantry was overloaded, and perhaps I did indulge in more than I should have ...but the morsels were soooo good going down! And eating did relieve my stress however momentarily.

I was bemoaning my condition rather loudly within earshot of your good Fr. Steve as he tried for quite a while to ignore me. He finally turned to me and quoted the above scripture passage. He said that instead of annoying him with my constant "whining" I should go out for a walk. WHINE?! ME?! I was not whining, I was merely communicating my discomfort to someone who should have been more sympathetic to a fellow creature of God! But that bit about going for a walk made me think that since it was such a nice day, a sort of slow saunter through the Stone Garden might be pleasant, and if I should just happen by Ruth's house, perhaps I could ask her to join me...mmm. I remembered that February 14th is Valentine's Day – it was marked on Fr. Steve's desktop calendar– and perhaps a pleasant hand-in-hand walk is just what we both need! Away I went!

I feel so much better now, thank you. Ruth and I have scheduled an every-other-evening stroll through the grounds and I don't know if it is the exercise or the company that has made me feel so good – perhaps a bit of both together does it. Ruth did suggest we walk every evening, but I reminded her that in all things we must chose "moderation!"



Until next month I remain your friend,
Joel Churchmouse

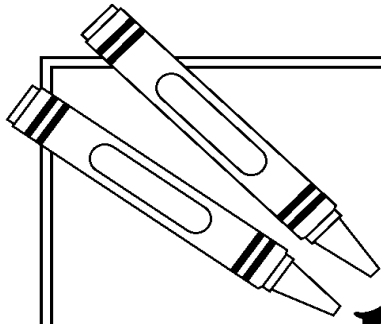

Just for **KIDS**

LOVE IS...

In 1 Corinthians 13 Paul writes about love. He tells us what love does and does not do. Let's find out about love!

Use the alphabet code to fill in the blanks.

| | | | | | | | | | | | | | | | | | | | | | | | | | |
|---|---|---|---|---|---|---|---|---|----|----|----|----|----|----|----|----|----|----|----|----|----|----|----|----|----|
| A | B | C | D | E | F | G | H | I | J | K | L | M | N | O | P | Q | R | S | T | U | V | W | X | Y | Z |
| 1 | 2 | 3 | 4 | 5 | 6 | 7 | 8 | 9 | 10 | 11 | 12 | 13 | 14 | 15 | 16 | 17 | 18 | 19 | 20 | 21 | 22 | 23 | 24 | 25 | 26 |

LOVE IS 16 1 20 9 5 14 20

LOVE IS 11 9 14 4

LOVE 18 5 10 15 9 3 5 19 WITH THE TRUTH

LOVE 16 18 15 20 5 3 20 19

LOVE 20 18 21 19 20 19

LOVE 8 15 16 5 19

LOVE 16 5 18 19 5 22 5 18 5 19

... THESE THREE REMAIN: FAITH, HOPE AND LOVE.
BUT THE GREATEST OF THESE IS

12 15 22 5

Answer: PATIENT, KIND, REJOICES, PROTECTS, TRUSTS, HOPES,
PERSEVERES, LOVE

February

2012

| Sunday | Monday | Tuesday | Wednesday | Thursday | Friday | Saturday |
|--------------------------------------------------------------------------------------------------------------------------------------------------------------------------------------------------------|-------------------------------------------------------|---------------------------------------------------------------------------------------------------|----------------------------------------------------------------------------------------------------|--------------------------|-------------------------------------|-------------------------------------------------------------------------------------------|
| | | | 1 12:30-2 pm YSC Noon HE & Healing 12-2 pm CIACC 5-7 pm FSG 8 pm AA | Groundhog Day | 3 | 4 |
| 5 8a.m. H.E. Chapel-Rt I 9:15-10:15 a.m. Church School & Adult Forum 10:30 a.m. HE-Rt II 12:00 - 12:40 pm Junior Choristers rehearsal Birthday Cake Sun. | 6 2 pm FINANCE Committee 5-9pm CASA | 7 9– noon Quilters 6:45-8 pm Salem Ringers 8 pm NA | 8 Noon HE & Healing 5-7 pm FSG 5 pm Liturgy Com Mtg in Library 8 pm AA | 9 5-9 pm CASA | 10 8:30-Noon – United Way | 11 9:30-3:30 Annual Diocesan Acolyte Festival at Trinity Cathedral in Trenton - |
| 12 8a.m. H.E. Chapel-Rt I 9:15-10:15 a.m. Church School & Adult Forum 10:30 a.m. HE-Rt II 12:00 - 12:40 pm Junior Choristers rehearsal ECW Sandwich Sun. 12:30 Vestry Mtg | 13 5-9pm CASA | 14 9– noon Quilters 6:45-8 pm Salem Ringers 8 pm NA Valentine's Day | 15 Noon HE & Healing 5-7 pm FSG 8 pm AA | 16 5-9 pm CASA | 17 | 18 |
| 19 TRANSFIGURATION 8a.m. H.E. Chapel-Rt I 9:15-10:15 a.m. Church School & Adult Forum 10:30 a.m. HE-Rt II 12:00 - 12:40 pm Junior Choristers rehearsal Donut Sunday | 20 5-9pm CASA Presidents' Day | 21 9– noon Quilters 6:45-8 pm Salem Ringers 5-7 pm PANCAKE SUPPER 8 pm NA | 22 ASH WEDNESDAY Noon & 7 PM HE & Imposition of Ashes 5-7 pm FSG 8 pm AA | 23 5-9 pm CASA | 24 | 25 7 pm Pictures and Pipes – Alloway Baptist Church |
| 26 LENT I 8a.m. H.E. Chapel-Rt I 9:15-10:15 a.m. Church School & Adult Forum 10:30 a.m. HE-Rt II 12:00 - 12:40 pm Junior Choristers rehearsal Pie Sunday Noon -ECW Mte | 27 5-9pm CASA | 28 9– noon Quilters 6:45-8 pm Salem Ringers 8 pm NA | 29 Noon HE & Healing 5-7 pm FSG 8 pm AA | | | |

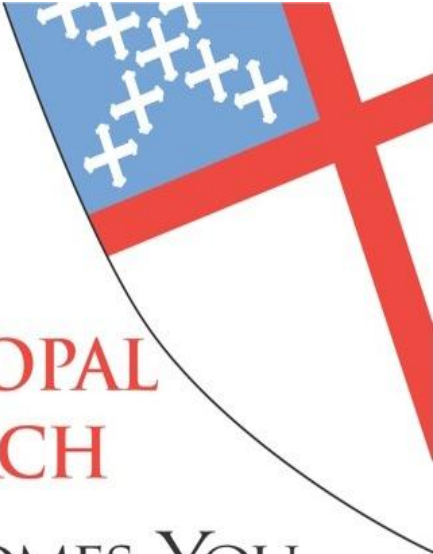

**THE
EPISCOPAL
CHURCH**

WELCOMES YOU

**St. John's Episcopal Church
Schedule**

Sunday:

- 8 a.m. Holy Eucharist, Rite I, in the Chapel
- 9:15 a.m. to 10:15 a.m. Sunday School and Adult Forum in Parish House
- 10:30 a.m. Holy Eucharist, Rite II, in the Church

Wednesday:

- Noon Holy Eucharist, Rite II, in the Chapel



St. John's Episcopal Church
76 Market Street
Salem, NJ 08079

ADDRESS CORRECTION REQUESTED

Dated Material –
Please Deliver Promptly

